

# ORPHEUS | N

## Non-Collinear Optical Parametric Amplifier

### FEATURES

- < 30 fs pulse duration
- Integrated pulse compressor
- Adjustable spectral bandwidth and pulse duration
- Wavelength feedback with internal spectrometer



ORPHEUS-N is a non-collinear optical parametric amplifier (NOPA). Depending on the model, ORPHEUS-N has an integrated second- or third-harmonic generator producing a 515 nm or 343 nm pump, respectively. ORPHEUS-N with a second-harmonic pump (ORPHEUS-N-2H) delivers < 30 fs pulses in the 700 – 850 nm range. ORPHEUS-N with a third harmonic pump (ORPHEUS-N-3H) delivers < 30 fs pulses in the 530 – 670 nm range. An optional second harmonic

generator is available, extending the tuning range down to ultraviolet (UV) spectral range.

Featuring a built-in prism-based pulse compressor, ORPHEUS-N is an invaluable instrument for ultrafast spectroscopy and nonlinear microscopy. A single PHAROS or CARBIDE femtosecond laser can pump multiple NOPAs providing pump and/or probe channels with independent wavelength tuning for your state-of-the-art experiments.

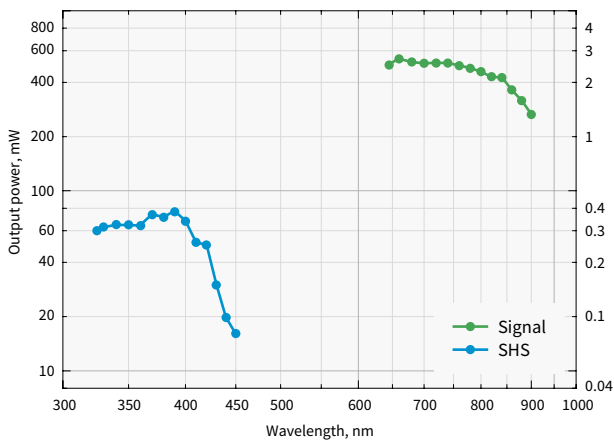

Typical tuning curves of **ORPHEUS-N-2H**  
Pump: 6 W, 30 µJ, 200 kHz

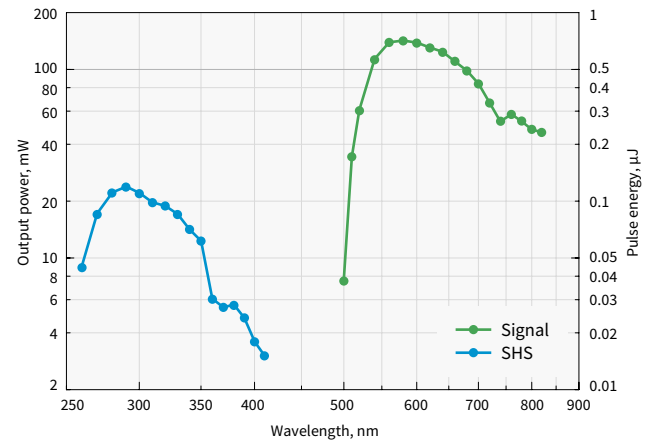

Typical tuning curves of **ORPHEUS-N-3H**  
Pump: 6 W, 30 µJ, 200 kHz

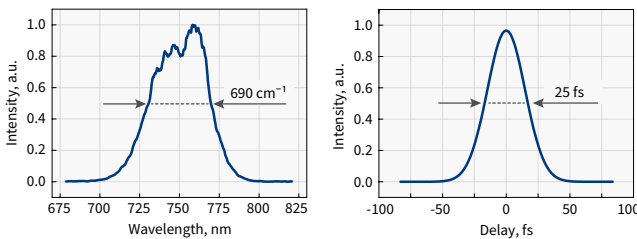

Typical output of **ORPHEUS-N-2H**

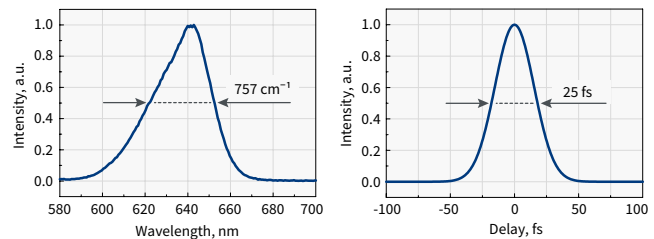

Typical output of **ORPHEUS-N-3H**

For custom tuning curves visit <http://toolbox.lightcon.com/tools/tuningcurves/>

## SPECIFICATIONS

Model	ORPHEUS-N-2H	ORPHEUS-N-3H
<b>OUTPUT FROM ORPHEUS-N</b>		
Tuning range	650 – 900 nm (Signal)	520 – 900 nm (Signal)
Maximum pump power	8 W	
Pump pulse energy	10 – 200 $\mu$ J	12 – 200 $\mu$ J
Conversion efficiency	> 7% @ 700 nm > 5% @ 800 nm	> 1.3% @ 580 nm > 0.7% @ 700 nm > 0.3% @ 800 nm
Integrated 2H / 3H generation efficiency <sup>1)</sup>	> 35% (515 nm)	> 25% (343 nm)
Pulse duration after compressor	< 30 fs @ 700 – 850 nm	< 30 fs @ 530 – 670 nm < 80 fs @ 670 – 900 nm
Long-term power stability, 8 h <sup>2)</sup>	< 2% @ 800 nm	< 2% @ 580 nm
Pulse-to-pulse energy stability, 1 min <sup>2)</sup>	< 2% @ 800 nm	< 2% @ 580 nm
<b>WAVELENGTH EXTENSIONS</b>		
Tuning range (SHS)	325 – 450 nm	260 – 450 nm
Conversion efficiency at peak	> 10% of Signal	

<sup>1)</sup> Not simultaneous to NOPA output.

<sup>2)</sup> Expressed as NRMSD (normalized root mean squared deviation).

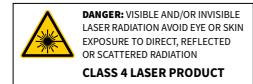

## DRAWINGS

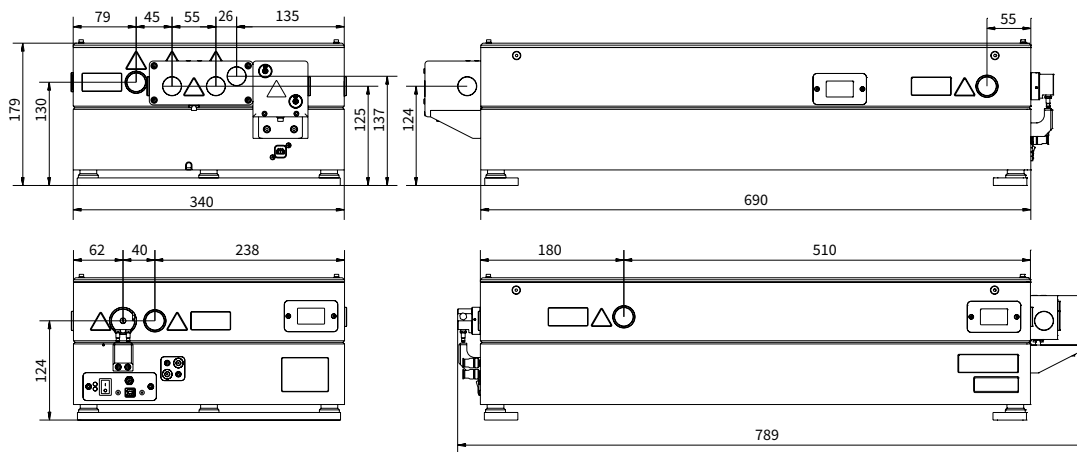

ORPHEUS-N drawings