

# PL2230 series



## Innovative design

The heart of the system is a diode pumped solid state (DPSS) master oscillator placed in a sealed monolithic block, producing high repetition rate pulse trains (87 MHz) with a low single pulse energy of several nJ. Diode pumped amplifiers are used for amplification of the pulse to 30 mJ or up to 40 mJ output. The high-gain regenerative amplifier has an amplification factor in the proximity of  $10^6$ . After the regenerative amplifier, the pulse is directed to a multipass power amplifier that is optimized for efficient stored energy extraction from the Nd:YAG rod, while maintaining a near Gaussian beam profile and low wavefront distortion. The output pulse energy can be adjusted in approximately 1% steps, while pulse-to-pulse energy stability remains at less than 0.5% rms at 1064 nm.

Angle-tuned KD\*P and KDP crystals mounted in thermostabilised ovens are used for second, third, and fourth harmonic generation. Harmonic separators ensure the high spectral purity of each harmonic guided to different output ports.

Built-in energy monitors continuously monitor output pulse energy. Data from the energy monitor can be seen on the remote keypad or on a PC monitor. The laser provides triggering pulses for the synchronisation of your equipment. The lead of the triggering pulse can be up to 500 ns and is user adjustable in  $\sim 0.25$  ns steps from a personal computer. Up to 1000  $\mu$ s lead of triggering pulse is available as a pretrigger feature. Precise pulse energy control, excellent short-term and long-term stability, and a 50 Hz repetition rate makes PL2230 series lasers an excellent choice for many demanding scientific applications.

## Simple and convenient laser control

For customer convenience the laser can be operated from master device or personal computer through USB (VCP, ASCII commands), RS232 (ASCII commands), LAN (REST API) or RS232 (ASCII commands), LAN (REST API) depending on the system configuration or from remote control pad with backlit display that is easy to read even while wearing laser safety glasses.

## Diode Pumped High Energy Picosecond Nd:YAG Lasers

### FEATURES

- ▶ Diode pumped power amplifier producing up to **40 mJ** per pulse at 1064 nm
- ▶ Beam profile improvement using advanced beam shaping system
- ▶ Hermetically sealed DPSS master oscillator
- ▶ Diode pumped regenerative amplifier
- ▶ Air-cooled
- ▶ **< 30 ps** pulse duration
- ▶ Excellent pulse duration stability
- ▶ Up to **100 Hz** repetition rate
- ▶ Streak camera triggering pulse with **< 10 ps** jitter
- ▶ Excellent beam pointing stability
- ▶ Thermo stabilized second, third or fourth harmonic generator options
- ▶ PC control
- ▶ Remote control via keypad

### APPLICATIONS

- ▶ Time resolved fluorescence (including streak camera measurements)
- ▶ SFG/SHG spectroscopy
- ▶ Nonlinear spectroscopy
- ▶ Laser-induced breakdown spectroscopy
- ▶ OPG pumping
- ▶ Remote laser sensing
- ▶ Satellite ranging
- ▶ Other spectroscopic and nonlinear optics applications

SPECIFICATIONS <sup>1)</sup>

Model	PL2230-100	PL2231-100	PL2231-50	PL2231A-50
<b>Pulse energy <sup>2)</sup></b>				
at 1064 nm	3 mJ	12 mJ	30 mJ	40 mJ
at 532 nm <sup>3)</sup>	1.3 mJ	5 mJ	13 mJ	18 mJ
at 355 nm <sup>4)</sup>	0.9 mJ	3.5 mJ	9 mJ	13 mJ
at 266 nm <sup>5)</sup>	0.3 mJ	1.2 mJ	3 mJ	5 mJ
at 213 nm <sup>6)</sup>	inquire			
<b>Pulse energy stability (StdDev) <sup>7)</sup></b>				
at 1064 nm	< 0.2 %		< 0.5 %	
at 532 nm	< 0.4 %		< 0.8 %	
at 355 nm	< 0.5 %		< 1.1 %	
at 266 nm	< 0.5 %		< 1.2 %	
at 213 nm	< 1.5 %		< 1.5 %	
Pulse duration (FWHM) <sup>8)</sup>	29 ± 4 ps			
Pulse duration stability <sup>9)</sup>	± 1 %			
Power drift <sup>10)</sup>	± 2 %			
Pulse repetition rate	0 – 100 Hz	100 Hz	50 Hz	50 Hz
Polarization	vertical, >99 % at 1064 nm			
Pre-pulse contrast	> 200 : 1 (peak-to-peak with respect to residual pulses)			
Beam profile <sup>11)</sup>	close to Gaussian in near and far fields			
Beam divergence <sup>12)</sup>	< 1.5 mrad		< 0.7 mrad	
Beam propagation ratio M <sup>2</sup>	< 1.3		< 2.5	
Beam pointing stability <sup>13)</sup>	≤ 10 μrad StdDev		≤ 20 μrad StdDev	
Typical beam diameter <sup>14)</sup>	~ 2 mm		~ 6 mm	~ 7 mm
<b>Optical pulse jitter</b>				
Internal triggering regime <sup>15)</sup>	<50 ps (StdDev) with respect to TRIG1OUT pulse			
External triggering regime <sup>16)</sup>	~3 ns (StdDev) with respect to SYNC IN pulse			
TRIG1 OUT pulse delay <sup>17)</sup>	-500 ... 50 ns			
Typical warm-up time	5 min		15 min	

**PHYSICAL CHARACTERISTICS**

Laser head size (W × L × H)	456×1031×249 ± 3 mm			
Electrical cabinet size (W × L × H)	12 V DC power adapter, 85×170×41 ± 3 mm	471×391×147 ± 3 mm		
Umbilical length	2.5 m			

**OPERATING REQUIREMENTS**

Cooling <sup>18)</sup>	stand-alone chiller			
Room temperature	22±2 °C			
Relative humidity	20 – 80 % (non-condensing)			
Power requirements	110–240 V AC, 50/60 Hz	Single phase, 110–240 V AC, 5 A, 50/60 Hz		
Power consumption	< 0.15 kVA	< 1.0 kVA		

<sup>1)</sup> Due to continuous improvement, all specifications are subject to change without notice. Parameters marked typical are not specifications. They are indications of typical performance and will vary with each unit we manufacture. Unless stated otherwise, all specifications are measured at 1064 nm and for basic system without options.

<sup>2)</sup> Outputs are not simultaneous.

<sup>3)</sup> For PL2230 series laser with -SH, -SH/TH, -SH/FH or -SH/TH/FH option or -SH/TH/FH/FiH module.

<sup>4)</sup> For PL2230 series laser with -TH, -SH/TH or -SH/TH/FH option or -SH/TH/FH/FiH module.

<sup>5)</sup> For PL2230 series laser with -SH/FH or -SH/TH/FH option or -SH/TH/FH/FiH module.

<sup>6)</sup> For PL2230 series laser with -SH/TH/FH/FiH module.

<sup>7)</sup> Averaged from pulses, emitted during 30 sec time interval.

<sup>8)</sup> FWHM. Inquire for optional pulse durations in 20 – 90 ps range. Pulse energy specifications may differ from indicated here.

<sup>9)</sup> Measured over 1 hour period when ambient temperature variation is less than ±1 °C.

<sup>10)</sup> Measured over 8 hours period after 20 min warm-up when ambient temperature variation is less than ± 2 °C.

<sup>11)</sup> Near field Gaussian fit is >80%.

<sup>12)</sup> Average of X- and Y-plane full angle divergence values measured at the 1/e<sup>2</sup> level at 1064 nm.

<sup>13)</sup> Beam pointing stability is evaluated from fluctuations of beam centroid position in the far field.

<sup>14)</sup> Beam diameter is measured at 1064 nm at the 1/e<sup>2</sup> level.

<sup>15)</sup> With respect to TRIG1 OUT pulse. <10 ps jitter is provided optionally with PRETRIG feature.

<sup>16)</sup> With respect to SYNC IN pulse.

<sup>17)</sup> TRIG1 OUT lead or delay can be adjusted with 0.25 ns steps in specified range.

<sup>18)</sup> Air cooled. Adequate room air conditioning should be provided.

If laser is optimised for pumping parametrical generator, maximum output energy may be different than specified for stand alone application.



Custom products, tailored for specific applications <sup>1)</sup>

Model	PL2231C-20 (inquire)
Pulse energy <sup>2)</sup>	
at 1064 nm	140 mJ
at 532 nm <sup>3)</sup>	60 mJ
at 355 nm <sup>4)</sup>	35 mJ
at 266 nm <sup>5)</sup>	15 mJ
Pulse duration (FWHM) <sup>6)</sup>	80 ps ± 10 %
Pulse repetition rate	20 Hz

<sup>1)</sup> Due to continuous improvement, all specifications are subject to change without notice. Parameters marked typical are not specifications. They are indications of typical performance and will vary with each unit we manufacture. Unless stated otherwise, all specifications are measured at 1064 nm and for basic system without options. Specifications for model PL2231C are preliminary and should be confirmed against quotation and purchase order.

<sup>2)</sup> Outputs are not simultaneous.

<sup>3)</sup> For PL2230 series laser with -SH, -SH/TH, -SH/FH or -SH/TH/FH option or -SH/TH/FH/FiH module.

<sup>4)</sup> For PL2230 series laser with -TH, -SH/TH or -SH/TH/FH option or -SH/TH/FH/FiH module.

<sup>5)</sup> For PL2230 series laser with -SH/FH or -SH/TH/FH option or -SH/TH/FH/FiH module.

<sup>6)</sup> FWHM. Inquire for optional pulse durations in 20 – 90 ps range. Pulse energy specifications may differ from indicated here.

OPTIONS

- **Option P20** provides 20 ps ±10% output pulse duration. Pulse energies are ~ 30 % lower in comparison to the 28 ps pulse duration version. See table below for pulse energy specifications:

Model	PL2231-50	PL2231A-50
1064 nm	23 mJ	28 mJ
532 nm	9 mJ	13 mJ
355 nm	6 mJ	9 mJ
266 nm	2 mJ	4 mJ

- **Option P80** provides 80 ps ± 10% output pulse duration. Pulse energy specifications are same as those of 28 ps lasers.
- **Option PLL** allows locking the master oscillator pulse train repetition rate to an external RF generator, enabling precise external triggering with low jitter. Inquire for more information.

BEAM PROFILE

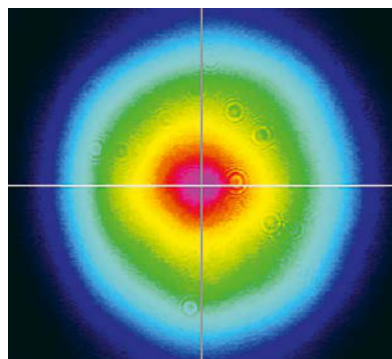

Fig 1. Typical near field output beam profile of PL2230 model laser

OUTLINE DRAWINGS

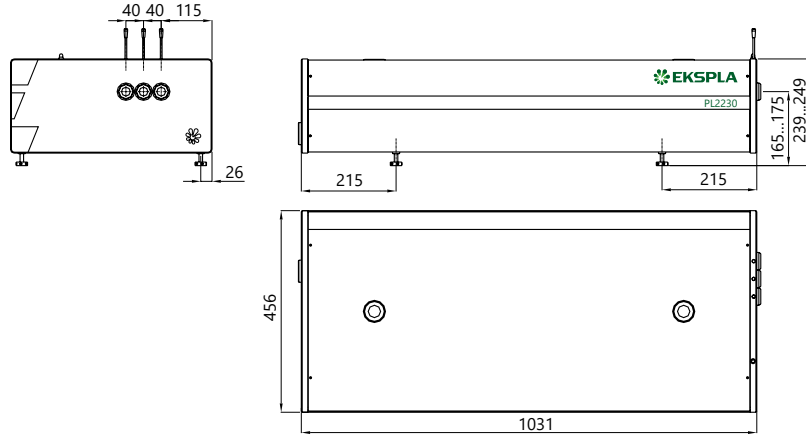

Fig 2. Dimensions of PL2230 series laser head

ORDERING INFORMATION

**Note:** Laser must be connected to the mains electricity all the time. If there will be no mains electricity for longer than 1 hour then laser (system) needs warm up for a few hours before switching on.

