

WAVELENGTH METER IN THE NEAR IR RANGE

SHR-IR

The SHR-IR wavelength meter is an ideal instrument for measuring absolute wavelength value of pulse and CW lasers and diodes in the spectral range 600 nm -1800 nm with accuracy better than $\lambda=20$ pm, as well as detecting FWHM of the analyzed line.



FEATURES

- Accuracy better than ± 20 pm
- Spectral range 600-1800 nm
- Real-time Spectrum & FWHM analysis
- Central wavelength continuous monitoring
- Ideal in wavelength control for CW and pulsed lasers
- Compact design; no moving components
- No calibration needed
- Optical fiber input; diffuse attenuator
- Power from USB cable

Apart from wavelength measuring the SHR-IR provides demonstration of analyzed spectra with resolution of 4 000 ($\lambda/\Delta\lambda$, FWHM) which constitutes 0.2 nm for 600 nm to 0.5 nm for 1800 nm. The SHR-IR also ensures on-line monitoring of the above values in the process of tuning the analyzed wavelength.

The instrument does not contain any moving elements; powering and control are performed from a computer via the Full-Speed USB interface. Analyzed light is steered to the entrance slit either via a multimode optical fiber with a diffuse attenuator (included in the delivery set) or directly, without any fibers.

In respect of resolution and wavelength measuring precision the SHR-NIR is an alternative to a monochromator-spectrograph with focal length not less than 500 mm, equipped with an appropriate IR-detector. Unlike the monochromator, the SHR-NIR has no moving elements and provides real-time measurements without scanning. The SHR-IR is rigid, stable and accurate, ensures absolute reliability and has more reasonable price. The SHR-IR spectrometer is indispensable in the process of adjustment, alignment and testing of laser systems operating in the near IR spectrum range.

SHR-IR SPECIFICATIONS

Optical scheme	Czerny-Turner
Physical principle	Echelle grating based
Operating modes	CW & Pulsed (externally triggered)
Focal length, mm	150
Aperture ratio	1:12
Spectral range, nm	600-1800
Wavelength detection accuracy, nm	± 0.02
Spectral resolution ($\lambda/\Delta\lambda_{FWHM}$)	4000 ($\Delta\lambda_{FWHM}$ from 0.15 nm @600 nm to 0.48 nm @1800 nm)
Source linewidth requirements, not above	$\leq 125 \text{ cm}^{-1}$ (4 nm for $\lambda = 600 \text{ nm}$ to 40 nm for $\lambda = 1800 \text{ nm}$)
Optical Interface	- Quartz optical fiber $\varnothing 600 \mu\text{m}$, 1m long, SMA-905 connector - Diffuse attenuator FA-3 with SMA-905 connector
Bec, κr	1,2
Computer Interface	Full Speed USB
Software	WLMeter
Dimensions, mm	142 x 110 x 80
Weight, kg	1.2

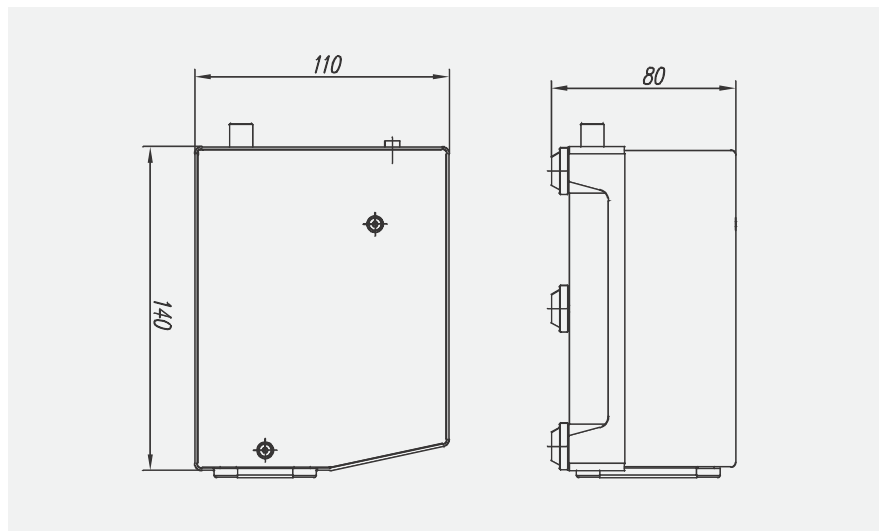

SHR-IR dimensions.

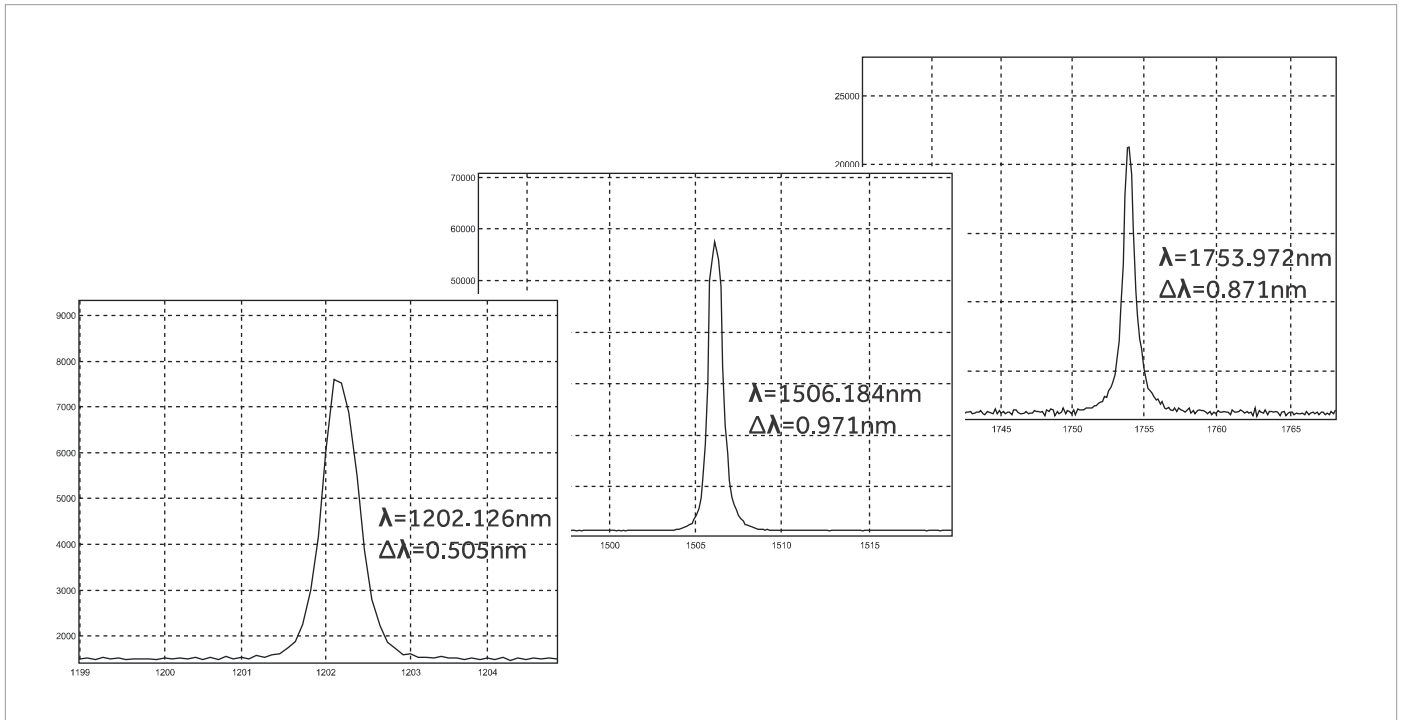

Optical parametric oscillator (OPO). Idler wave.
Real-time measurements at tuning laser wavelength.

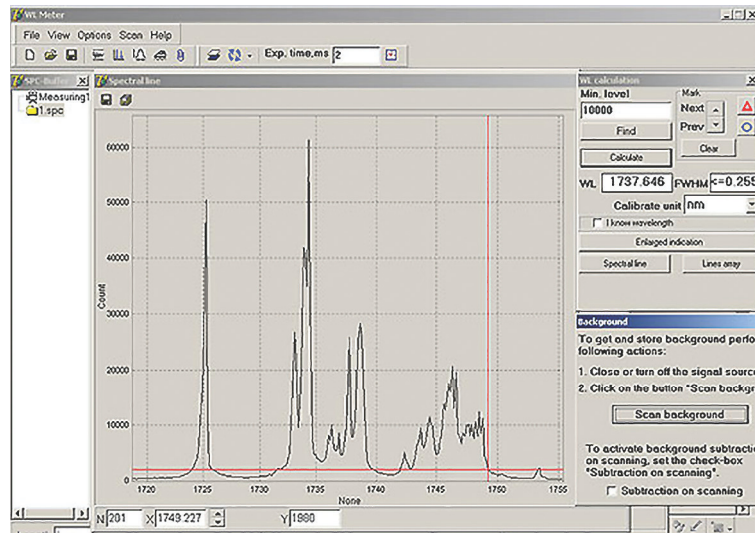

1725–1750 nm laser diode spectrum acquired with the SHR-IR.